

Smart Battery Combiner (ME-SBC)

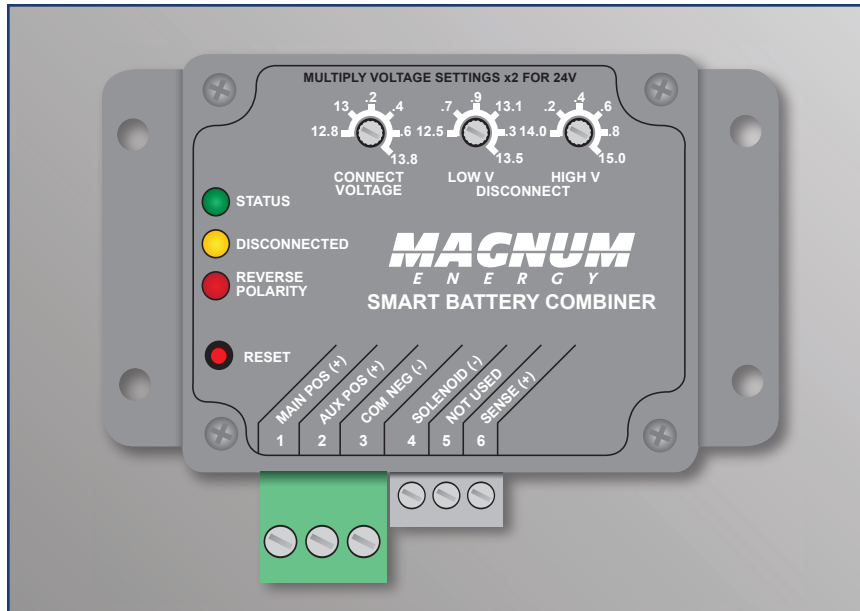

The Magnum Energy Smart Battery Combiner (ME-SBC) is an easy-to-use stand alone battery combiner and isolator for 12 and 24 VDC systems. Apply a single charging source to the main battery bank and the ME-SBC charges a second battery bank using a portion of the current. With adjustable voltage ranges, including automatic on off setpoints, the ME-SBC prevents under- or over-charging.

MODEL NUMBER

- ME-SBC

AVAILABLE FOR

- Renewable Energy Systems
Off-grid Power
Back-up Power
- Marine Systems
- RV Systems

The Front Panel Includes:

- LED indicators showing status and operation.
- Three adjustable voltage dials to set the “Connect Voltage”, “Low V Disconnect”, and “High V Disconnect.”
- An oversized power terminal block allowing for easy wire connections even if the wires are large.
- An accessories terminal block to add a solenoid or a separate voltage sense line.
- A reset switch to restore factory settings.

Features:

- Voltage auto-detect feature recognizing 12 or 24 VDC.
- Transfers up to 25 amps.
- Solenoid drive for requirements greater than 25 amps.
- Over-temperature and over-current shutdown.
- Adjustable voltage settings with a wide range allows for charging flexibility.
- Bi-directional charging.
- Reverse polarity protection.
- Sense lead for long-run applications.

ME-SBC Basic Configuration Diagrams

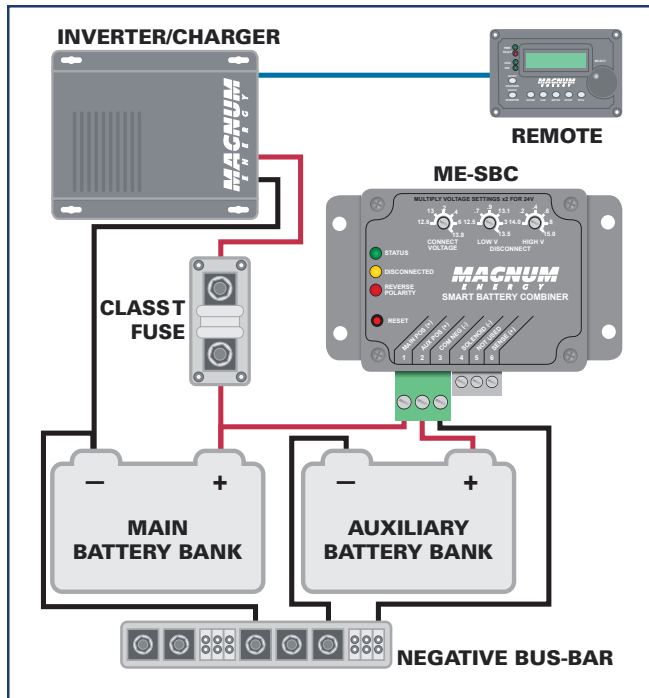

25 amp Combiner Mode

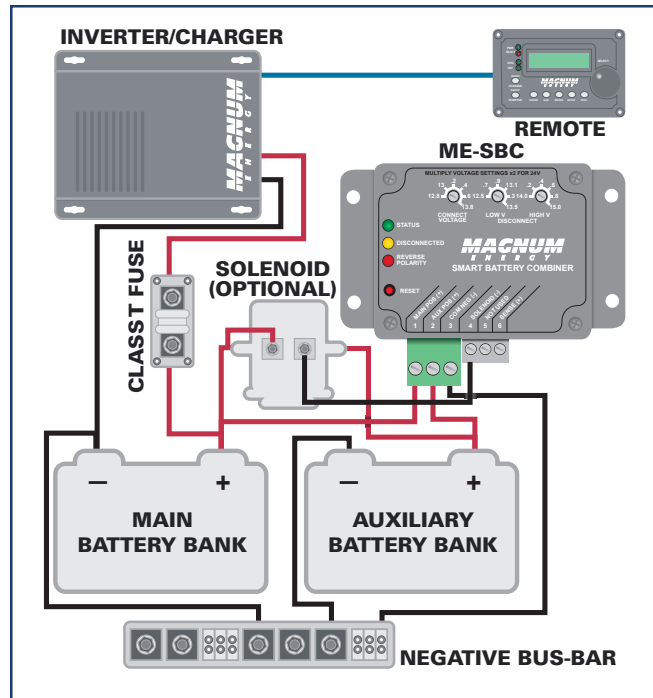

Solenoid Drive

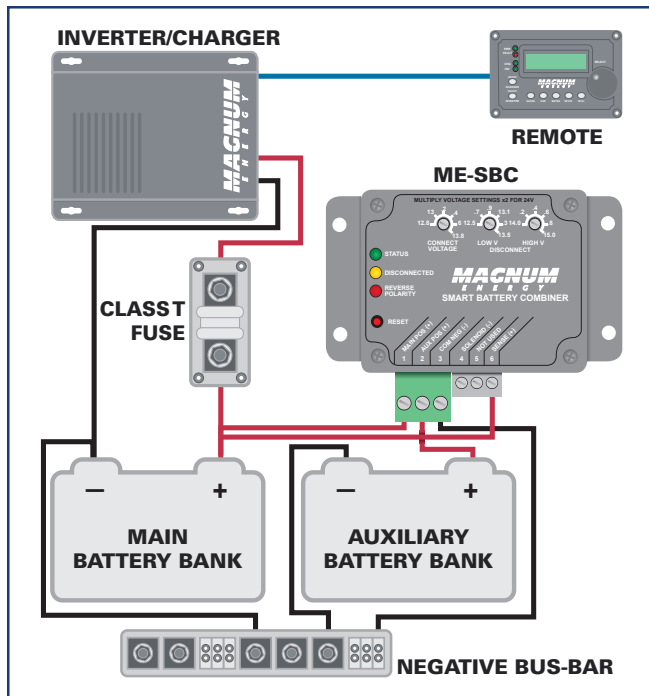

Remote Voltage Sense

ME-SBC Specifications

ME-SBC	
DC volts	12 or 24 VDC nominal
DC amps	25 amps continuous
Maximum VDC	40 volts peak
Average operating tare loss	~150 mW
Maximum operating tare loss	< 220 mW
Non-operating tare loss	< 50 mW
Operating range	0 - 32 VDC
Shipping weight	2 lbs (0.9 kg)
Shipping dimensions (l x w x h)	6" x 9" x 2.5" (15.2 x 22.9 x 6.4 cm)
Unit dimensions (l x w x h)	4.2" x 5.4" x 1.4" (10.7 x 13.7 x 3.6 cm)
Maximum operating temperature	-40° F to +185° F (-40° C to + 85° C)
Maximum storage temperature	-40° F to +194° F (-40° C to + 90° C)

Magnum Energy, Inc.
2211 West Casino Road
Everett, Washington 98204 USA

Phone: 425-353-8833
Fax: 425-353-8390
Web: www.magnumenergy.com

Testing for specifications at 25° C
Specifications subject to change without notice.

February 2009, Rev A

Part #xx-xxxx

Authorized Magnum Dealer